

# HCG - HORN Catalog Guide

Bore Ø	Product line								
	105	110	108	10P	111	11P	114	116	18P
≥ .008" (0.2 mm)	•								
≥ .236" (6.0 mm)	•	•							
≥ .268" (6.8 mm)	•	•							
≥ .307" (7.8 mm)		•	•						
≥ .315" (8.0 mm)		•	•						
≥ .346" (8.8 mm)				•					
≥ .354" (9.0 mm)		•	•	•					
≥ .386" (9.8 mm)					•	•			
≥ .394" (10.0 mm)		•		•	•				
≥ .419" (10.5 mm)						•			
≥ .433" (11.0 mm)					•	•			
≥ .492" (12.5 mm)							•		
≥ .551" (14.0 mm)							•	•	
≥ .630" (16.0 mm)								•	
≥ .650" (16.5 mm)							•		
≥ .689" (17.5 mm)									•

Groove depth ≤ (inch)	.098"	.157"	.039"	.118"	.091"	.138"	.256"	.169"	.315"
Groove depth ≤ (mm)	2.5	4.0	1.0	3.0	2.3	3.5	6.5	4.3	8.0
Width of groove inch	.020"-.079"	.039"-.250"	.029"-.079"	.039"-.118"	.029"-.125"	.039"-.118"	.029"-.125"	.029"-.157"	.071"-.118"
Width of groove mm	0.5 - 2.0	1.0 - 6.35	0.74 - 2.0	1.0 - 3.0	0.74 - 3.18	1.0 - 3.0	0.74 - 3.18	0.74 - 4.0	1.8 - 3.0

Application	Product line								
	105	110	108	10P	111	11P	114	116	18P
Grooving	•	•	•	•	•	•	•	•	•
Boring	•	•	•	•	•	•	•	•	•
Threading	•		•		•		•	•	
Chamfering	•		•		•		•	•	
Face Grooving	•	•					•		
Hard turning	•		•		•		•	•	

Chapter	<b>A</b>	<b>B</b>	<b>C</b>	<b>D</b>	<b>E</b>	<b>F</b>	<b>G</b>	<b>H</b>	<b>J</b>
---------	----------	----------	----------	----------	----------	----------	----------	----------	----------

Special tools upon request

## MINI CARBIDE GROOVING TOOLS

Toolholder  
**BU10P / B10P**



Page D2-D5

Inserts  
**10P / S10P**  
≥ Ø .354" (9.0 mm)

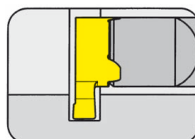

Page D6, D8

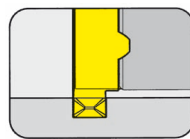

Page D7, D9

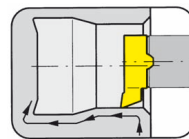

Page D10

Technical Instructions

Page L1 - L9

## TOOLHOLDER Type

## BU10P

with through coolant supply

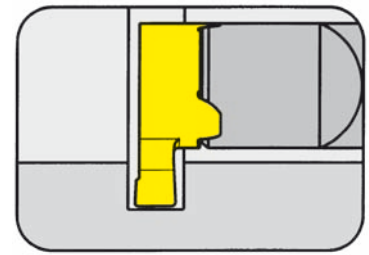

Bore Ø from	.354"
Depth of groove up to	.118"
Width of groove up to	.118"

Material of shank: Carbide - Giving a good vibration resistance

for use with Insert

Type 10P  
S10P

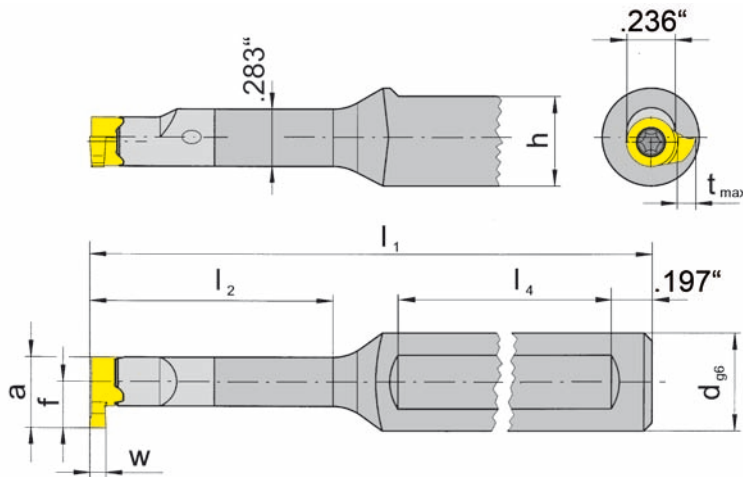

R = right hand version shown

L = left hand version

Part number	d	l <sub>1</sub>	l <sub>2</sub>	h	l <sub>4</sub>
R/LBU10P.0500.00		2.756	.492		1.575
R/LBU10P.0500.01	.500	3.150	.827	.461	1.772
R/LBU10P.0500.02		3.543	1.181		1.772

State R or L version

w, a, t<sub>max</sub> and f see inserts

Dimensions in inch

Further sizes upon request

### Ordering note:

Toolholders with damaged seating can be repaired by HORN.

### Spare parts

Toolholder	Screw	TORX PLUS® Wrench
R/LBU10P.0500.0...	2.6.5T8EP	T8PL

## TOOLHOLDER Type

# B10P

with through coolant supply

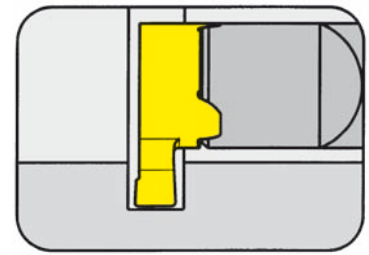

Bore Ø from	.354" (9.0 mm)
Depth of groove up to	.118" (3.0 mm)
Width of groove up to	.118" (3.0 mm)

Material of shank: Carbide - Giving a good vibration resistance

for use with Insert

Type 10P  
S10P

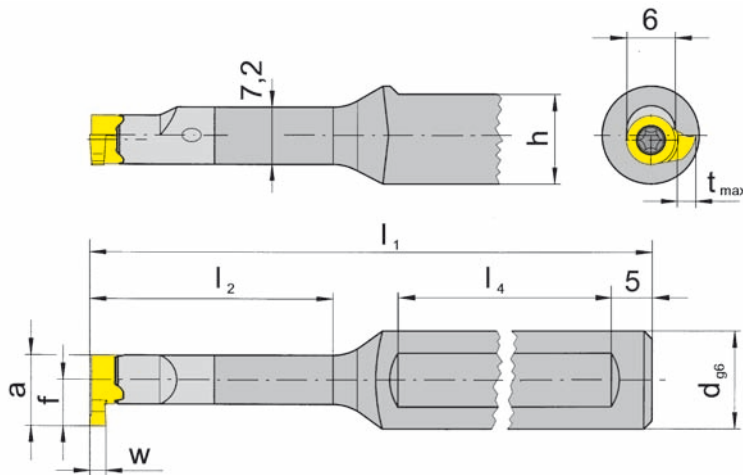

R = right hand version shown

L = left hand version

Part number	d	l <sub>1</sub>	l <sub>2</sub>	h	l <sub>4</sub>
R/LB10P.0012.00	12	70	12.5	11	40
R/LB10P.0012.01		80	21.0		45
R/LB10P.0012.02		90	30.0		45

State R or L version

w, a, t<sub>max</sub> and f see inserts

Dimensions in mm

Further sizes upon request

### Ordering note:

Toolholders with damaged seating can be repaired by HORN.

### Spare parts

Toolholder	Screw	TORX PLUS® Wrench
R/LB10P.0012.0...	2.6.5T8EP	T8PL

## TOOLHOLDER Type

# B10P

with through coolant supply

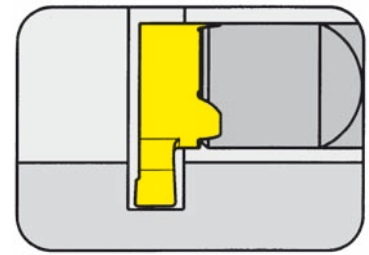

Bore Ø from	.354" (9.0 mm)
Depth of groove up to	.118" (3.0 mm)
Width of groove up to	.118" (3.0 mm)

Material of shank: Carbide - Giving a good vibration resistance

for use with Insert

Type 10P  
S10P

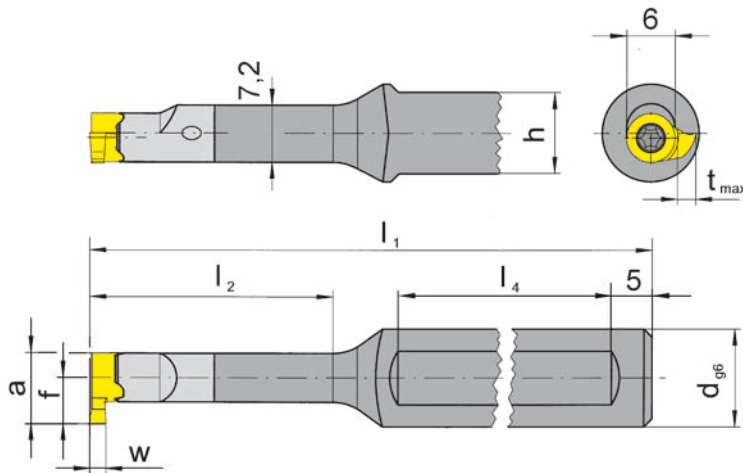

R = right hand version shown

L = left hand version

with 2 clamping flats

Part number	d	l <sub>1</sub>	l <sub>2</sub>	h	l <sub>4</sub>
R/LB10P.0012.2.00	12	70	12.5	11	40
R/LB10P.0012.2.01	12	80	21.0	11	45
R/LB10P.0012.2.02	12	90	30.0	11	45

State R or L version

w, a, t<sub>max</sub> and f see inserts

Dimensions in mm

Further sizes upon request

### Ordering note:

Toolholders with damaged seating can be repaired by HORN.

### Spare parts

Toolholder	Screw	TORX PLUS® Wrench
R/LB10P.0012.2.0...	2.6.5T8EP	T8PL

## TOOLHOLDER Type

# B10P

with through coolant supply

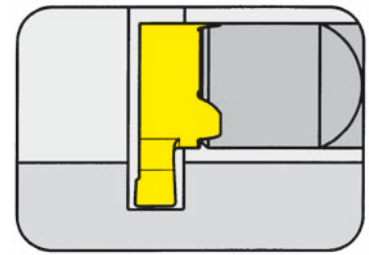

Bore Ø from	.354" (9.0 mm)
Depth of groove up to	.118" (3.0 mm)
Width of groove up to	.118" (3.0 mm)

Material of shank: Carbide - Giving a good vibration resistance

for use with Insert

Type 10P  
S10P

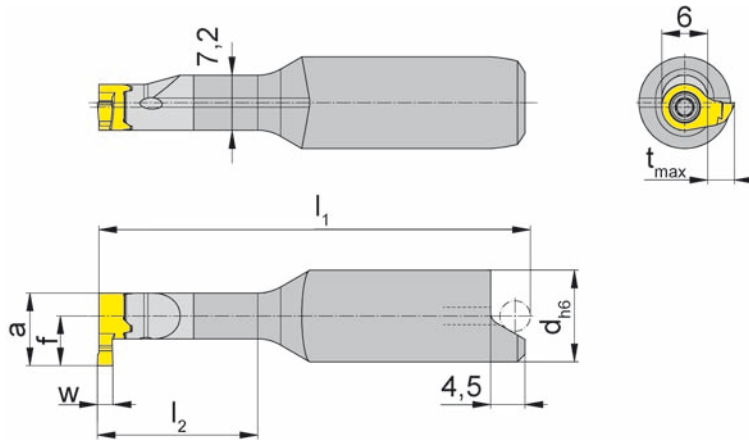

R = right hand version shown

L = left hand version

for shrinkage location  
S = orientation

Part number	d	l <sub>1</sub>	l <sub>2</sub>
R/LB10P.0012.00S	12	48.7	12.5
R/LB10P.0012.01S		56.7	21.0
R/LB10P.0012.02S		65.7	30.0

State R or L version

w, a, t<sub>max</sub> and f see inserts

Dimensions in mm

Further sizes upon request

### Ordering note:

Toolholders with damaged seating can be repaired by HORN.

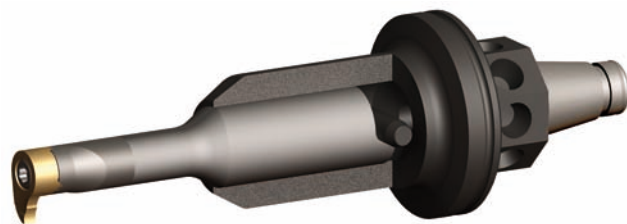

Example of assembly System „W&F“

### Spare parts

Toolholder	Screw	TORX PLUS® Wrench
R/LB10P.0012.0...	2.6.5T8EP	T8PL

# GROOVING (internal) $\geq \text{Ø} .354''$



INSERT Type

## 10P

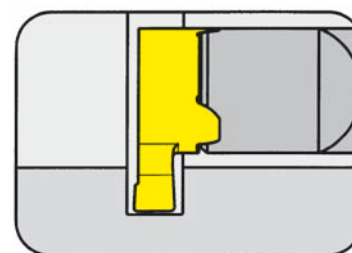

Bore Ø from	.354"
Depth of groove up to	.079"
Width of groove	.039 - .118"

for use with Toolholder

Type B10P  
BU10P

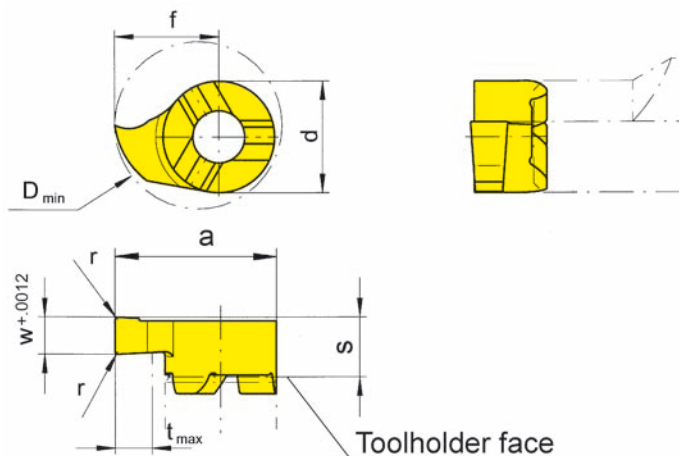

R = right hand version shown

L = left hand version

Part number	w	r	s	f	a	d	t <sub>max</sub>	D <sub>min</sub>	MG12	TN35	TI25	TH35
R/L10P.0100.1.00	.039	-										▲▲
R/L10P.0150.1.00	.059	-										▲▲
R/L10P.0200.1.02	.079	.008	.142	.217	.335	.236	.079	.354				▲▲
R/L10P.0250.1.02	.098	.008										▲▲
R/L10P.0300.1.02	.118	.008										▲▲
									P			•
									M			•
									K			•
									S			•
									N			•
									H			

- ▲ on stock Δ 4 weeks
- main recommendation
- o alternative recommendation
- uncoated grades
- coated grades
- brazed/Cermet

Dimensions in inch

State R or L version

Carbide grades

# GROOVING (internal) $\geq \text{Ø} .354''$



INSERT Type

## S10P

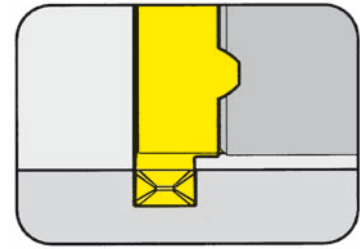

for use with Toolholder

Type B10P  
BU10P



Bore Ø from	.354"
Depth of groove up to	.079"
Width of groove	.039 - .079"

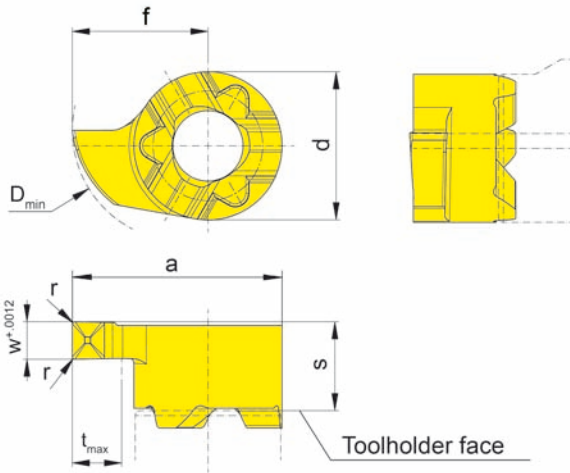

R = right hand version shown

L = left hand version

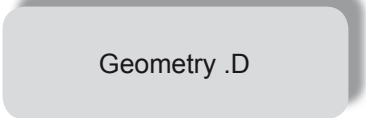

Part number	w	r	s	f	a	d	t <sub>max</sub>	D <sub>min</sub>	Carbide grades			
									MG12	TN35	TI25	TH35
R/LS10P.0100.1.D1	.039	.004										▲▲
R/LS10P.0150.1.D1	.059	.004	.142	.217	.335	.236	.079	.354				▲▲
R/LS10P.0200.1.D2	.079	.008										▲▲
									P			•
									M			•
									K			•
									S			•
									N			•
									H			•

- ▲ on stock Δ 4 weeks
- main recommendation
- o alternative recommendation
- uncoated grades
- coated grades
- brazed/Cermet

Dimensions in inch

State R or L version

Carbide grades

# GROOVING (internal) $\geq \text{Ø} .394''$



INSERT Type

## 10P

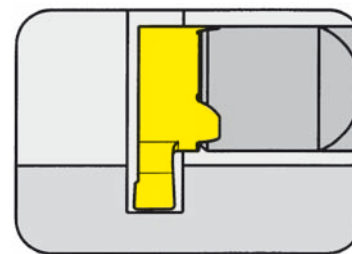

Bore Ø from	.394"
Depth of groove up to	.118"
Width of groove	.039 - .079"

for use with Toolholder

Type B10P  
BU10P

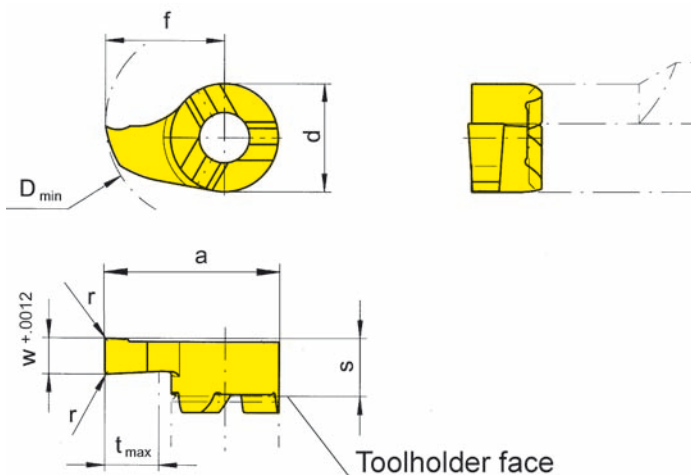

R = right hand version shown

L = left hand version

Part number	w	r	s	f	a	d	t <sub>max</sub>	D <sub>min</sub>	Carbide grades				
									MG12	TN35	TI25	TH35	
R/L10P.0100.2.00	.039	-										▲▲	●
R/L10P.0150.2.00	.059	-	.142	.256	.374	.236	.118	.394				▲▲	●
R/L10P.0200.2.02	.079	.008										▲▲	●
										P			●
										M			●
										K			●
										S			●
										N			●
										H			

- ▲ on stock Δ 4 weeks
- main recommendation
- alternative recommendation
- uncoated grades
- coated grades
- brazed/Cermet

Dimensions in inch

State R or L version

Carbide grades

# GROOVING (internal) $\geq \text{Ø} .394''$



INSERT Type

## S10P

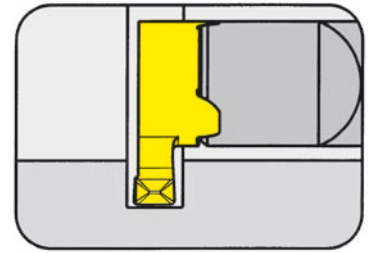

Bore Ø from	.394"
Depth of groove up to	.118"
Width of groove	.059 - .079"

for use with Toolholder

Type B10P  
BU10P

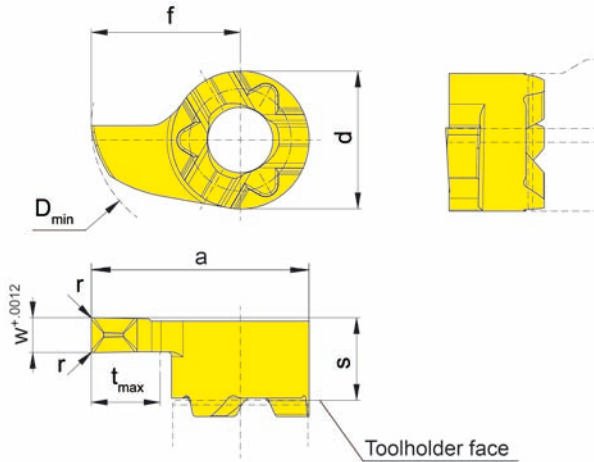

R = right hand version shown

L = left hand version

Geometry .D

Part number	w	r	s	f	a	d	t <sub>max</sub>	D <sub>min</sub>	Carbide grades			
									MG12	TN35	TI25	TH35
R/LS10P.0150.2.D1	.059	.004	.142	.256	.374	.236	.118	.394				▲▲
R/LS10P.0200.2.D2	.079	.008	.142	.256	.374	.236	.118	.394				▲▲
									P			•
									M			•
									K			•
									S			•
									N			•
									H			•

- ▲ on stock Δ 4 weeks
- main recommendation
- o alternative recommendation
- uncoated grades
- coated grades
- brazed/Cermet

Dimensions in inch  
State R or L version

Carbide grades



## INSERT Type

# S10P

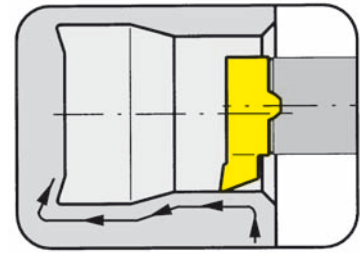

for use with Toolholder

Type B10P  
BU10P

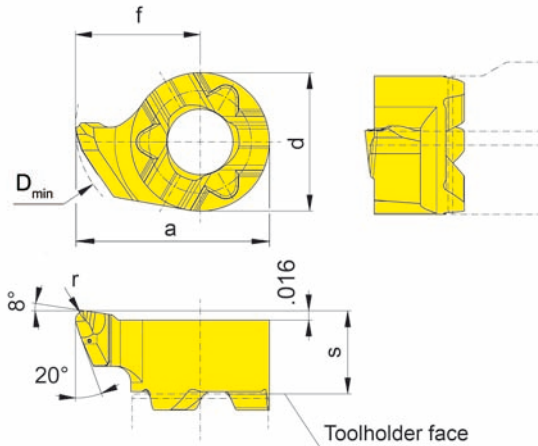

R = right hand version shown

L = left hand version

Geometry .R

Part number	r	s	f	a	d	D <sub>min</sub>	Carbide grades			
							MG12	TN35	Ti25	TH35
LS10P.1854.R2	.008									▲
RS10P.1854.R2	.008					.346				▲
LS10P.1854.R4	.016	.142	.213	.331	.236					▲
RS10P.1854.R4	.016									▲
							P			•
							M			•
							K			•
							S			•
							N			•
							H			•

- ▲ on stock Δ 4 weeks
- main recommendation
- o alternative recommendation
- uncoated grades
- coated grades
- brazed/Cermet

Dimensions in inch

State R or L version

The modified geometry allows boring of bores  $\geq \text{Ø} .346''$  and profiling of reliefs as per DIN 509 form E and F.

PCD- or CBN-tipped inserts upon request.

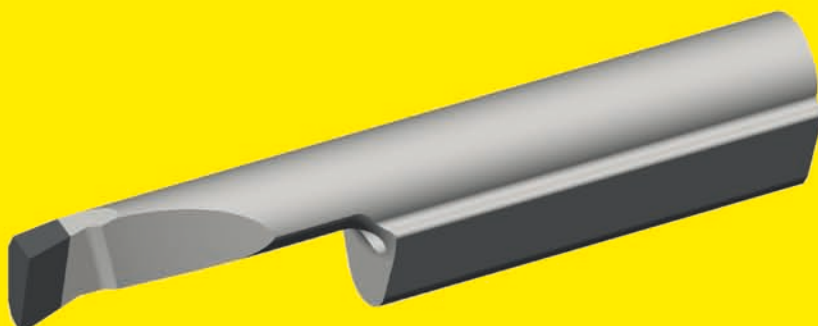

## Supermini®

Turning of hardened parts  
from bore  $\varnothing > .118"$

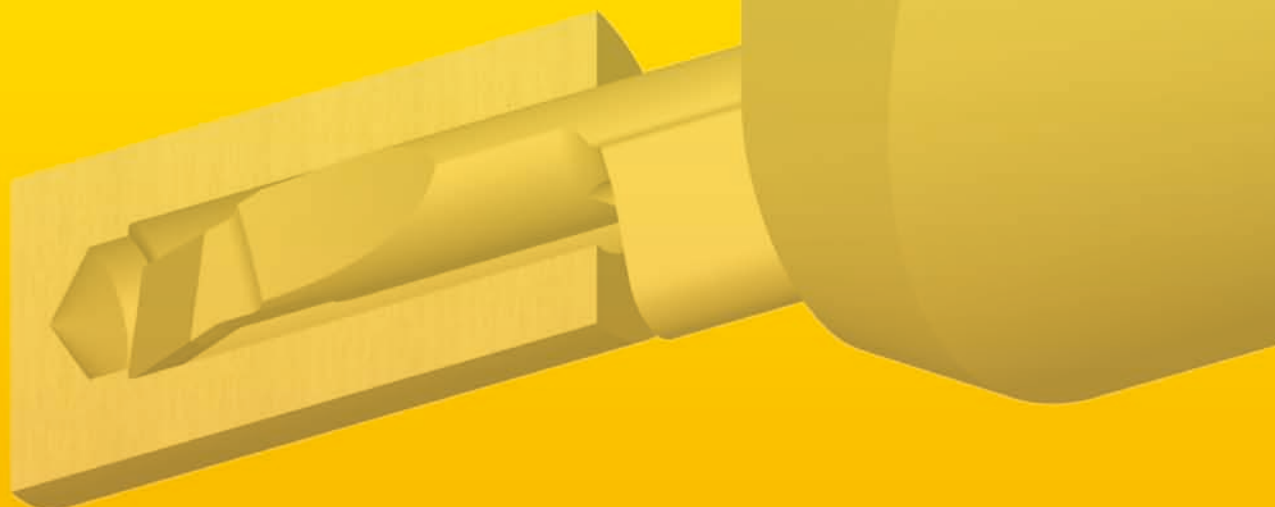

**MINI**  
PCD-tipped insert



D

D11