

HCG - HORN Catalog Guide

Bore Ø	Product line								
	105	110	108	10P	111	11P	114	116	18P
≥ .008" (0.2 mm)	•								
≥ .236" (6.0 mm)	•	•							
≥ .268" (6.8 mm)	•	•							
≥ .307" (7.8 mm)		•	•						
≥ .315" (8.0 mm)		•	•						
≥ .346" (8.8 mm)				•					
≥ .354" (9.0 mm)		•	•	•					
≥ .386" (9.8 mm)					•	•			
≥ .394" (10.0 mm)		•		•	•				
≥ .419" (10.5 mm)						•			
≥ .433" (11.0 mm)					•	•			
≥ .492" (12.5 mm)							•		
≥ .551" (14.0 mm)							•	•	
≥ .630" (16.0 mm)								•	
≥ .650" (16.5 mm)							•		
≥ .689" (17.5 mm)									•

Groove depth ≤ (inch)	.098"	.157"	.039"	.118"	.091"	.138"	.256"	.169"	.315"
Groove depth ≤ (mm)	2.5	4.0	1.0	3.0	2.3	3.5	6.5	4.3	8.0
Width of groove inch	.020"-.079"	.039"-.250"	.029"-.079"	.039"-.118"	.029"-.125"	.039"-.118"	.029"-.125"	.029"-.157"	.071"-.118"
Width of groove mm	0.5 - 2.0	1.0 - 6.35	0.74 - 2.0	1.0 - 3.0	0.74 - 3.18	1.0 - 3.0	0.74 - 3.18	0.74 - 4.0	1.8 - 3.0

Application	Product line								
	105	110	108	10P	111	11P	114	116	18P
Grooving	•	•	•	•	•	•	•	•	•
Boring	•	•	•	•	•	•	•	•	•
Threading	•		•		•		•	•	
Chamfering	•		•		•		•	•	
Face Grooving	•	•					•		
Hard turning	•		•		•		•	•	

Chapter	A	B	C	D	E	F	G	H	J
---------	----------	----------	----------	----------	----------	----------	----------	----------	----------

Special tools upon request

MINI CARBIDE GROOVING TOOLS

Toolholder
BU18P / B18P



Page J2-J3

Inserts
18P / S18P
≥ Ø .709" (18 mm)

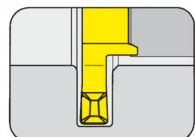

Page J4, J6

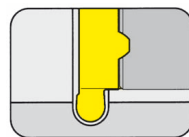

Page J5

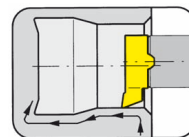

Page J7

Technical Instructions

Page L1 - L9

J

TOOLHOLDER Type

BU18P

with through coolant supply

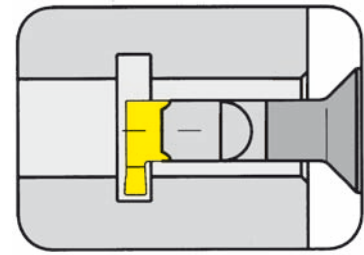

Bore Ø from	.709"
Depth of groove up to	.315"
Width of groove up to	.118"

Material of shank: Carbide - Giving a good vibration resistance

for use with Insert

Type 18P
S18P

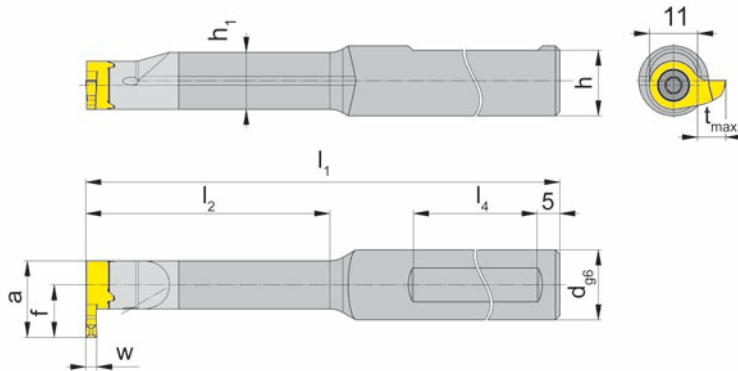

R = right hand version shown

L = left hand version

Part number	d	l ₁	l ₂	h	h ₁	l ₄
R/LBU18P.0500.00	.500	3.937	.984	.461	.500	1.969
R/LBU18P.0500.01		4.724	1.575			
R/LBU18P.0625.00	.625	3.937	.984	.585	.512	1.969
R/LBU18P.0625.01		4.724	1.575			
R/LBU18P.0625.02		5.118	2.205			
R/LBU18P.0625.03		5.906	3.150			

State R or L version

w, a, t_{max} and f see inserts

Dimensions in inch

Further sizes upon request

Ordering note:

Toolholders with damaged seating can be repaired by HORN.

Spare parts

Toolholder	Screw	TORX PLUS® Wrench
R/LBU18P.0...	5.13T20EP	T20PQ

TOOLHOLDER Type

B18P

with through coolant supply

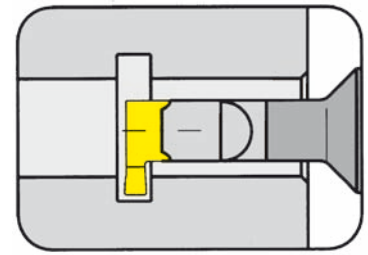

Bore Ø from	.709" (18.0 mm)
Depth of groove up to	.315" (8.0 mm)
Width of groove up to	.118" (3.0 mm)

Material of shank: Carbide - Giving a good vibration resistance

for use with Insert

Type 18P
S18P

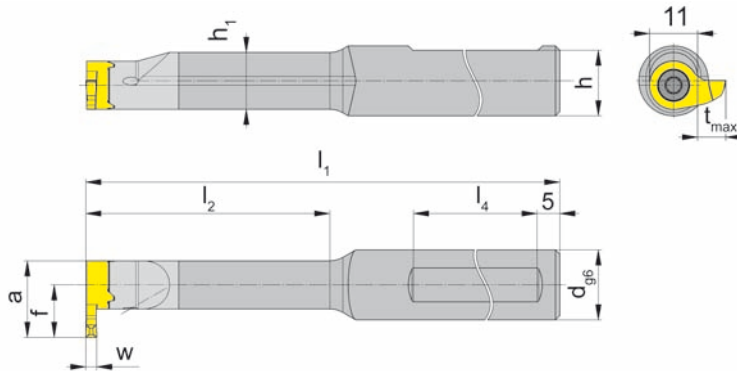

R = right hand version shown

L = left hand version

Part number	d	l ₁	l ₂	h	h ₁	l ₄
R/LB18P.0012.00 R/LB18P.0012.01	12	100 120	25 40	11	12.5	50
R/LB18P.0016.00 R/LB18P.0016.01 R/LB18P.0016.02 R/LB18P.0016.03	16	100 120 130 150	25 40 56 80	15	13.0	50

State R or L version

w, a, t_{max} and f see inserts

Dimensions in mm

Further sizes upon request

Ordering note:

Toolholders with damaged seating can be repaired by HORN.

Spare parts

Toolholder	Screw	TORX PLUS® Wrench
R/LB18P.001...	5.13T20EP	T20PQ



GROOVING (internal) $\geq \text{Ø} .709''$



INSERT Type

S18P

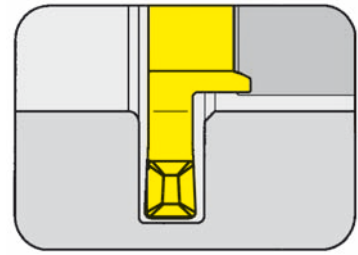

Bore Ø from	.709"
Depth of groove up to	.236"
Width of groove	.079 - .118"

for use with Toolholder

Type B18P
BU18P

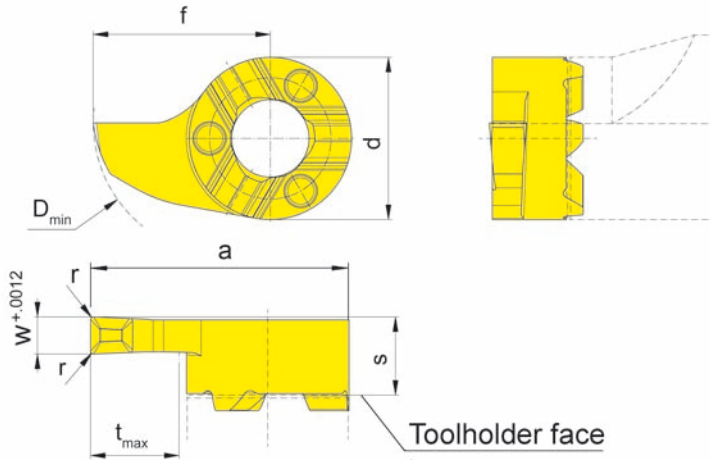

R = right hand version shown

L = left hand version

Part number	w	r	s	f	a	d	t _{max}	D _{min}	Carbide grades			
									MG12	TN35	TI25	TH35
R/LS18P.0200.1.D2	.079											▲▲
R/LS18P.0250.1.D2	.098	.008	.209	.472	.689	.433	.236	.709				▲▲
R/LS18P.0300.1.D2	.118											▲▲
									P			•
									M			•
									K			•
									S			•
									N			•
									H			•

- ▲ on stock Δ 4 weeks
- main recommendation
- o alternative recommendation
- uncoated grades
- coated grades
- brazed/Cermet

Dimensions in inch

State R or L version

Carbide grades

GROOVING (internal) $\geq \text{Ø} .709''$



INSERT Type

18P

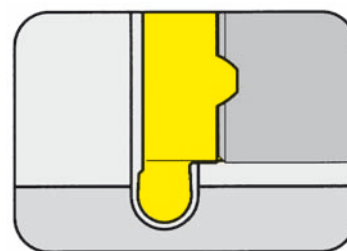

Bore Ø from	.709"
Depth of groove up to	.236"
Width of groove	.071 - .118"

for use with Toolholder

Type B18P
BU18P

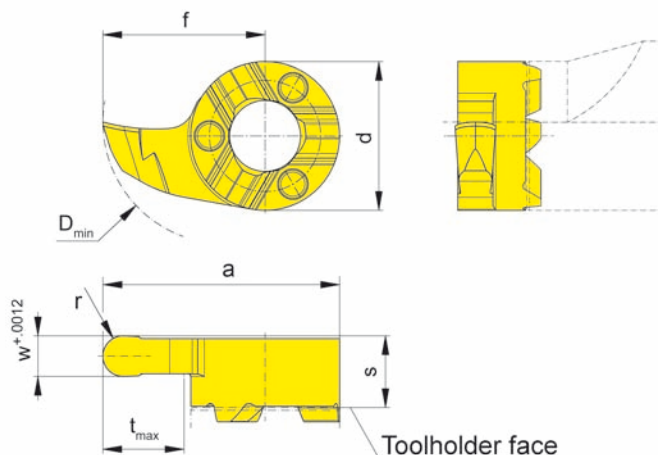

R = right hand version shown

L = left hand version

Full radius

Part number	w	r	s	f	a	d	t _{max}	D _{min}	Carbide grades			
									MG12	TN35	TI25	TH35
R/L18P.0009.1.18	.071	.035										▲▲
R/L18P.0011.1.22	.087	.043	.209	.472	.689	.433	.236	.709				▲▲
R/L18P.0015.1.30	.118	.059										▲▲
									P			•
									M			•
									K			•
									S			•
									N			•
									H			•

- ▲ on stock Δ 4 weeks
- main recommendation
- o alternative recommendation
- uncoated grades
- coated grades
- brazed/Cermet

Dimensions in inch
State R or L version



Carbide grades

GROOVING (internal) $\geq \text{Ø} .787''$



INSERT Type

S18P

Bore Ø from	.787"
Depth of groove up to	.315"
Width of groove	.079 - .118"

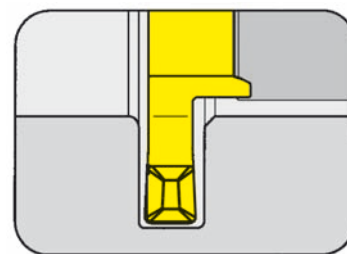

for use with Toolholder

Type B18P
BU18P

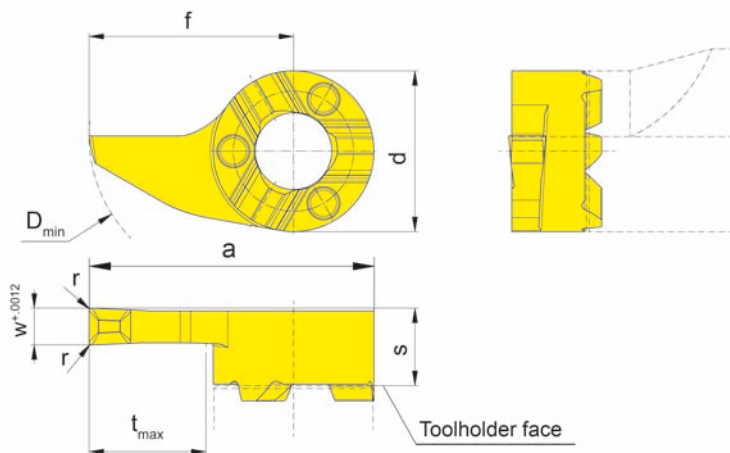

R = right hand version shown

L = left hand version

Part number	w	r	s	f	a	d	t _{max}	D _{min}	Carbide grades				
									MG12	TN35	TI25	TH35	
R/LS18P.0200.2.D2	.079											▲▲	▲▲
R/LS18P.0250.2.D2	.098	.008	.209	.551	.768	.433	.315	.787				▲▲	▲▲
R/LS18P.0300.2.D2	.118											▲▲	▲▲
										P			•
										M			•
										K			•
										S			•
										N			•
										H			•

- ▲ on stock Δ 4 weeks
- main recommendation
- o alternative recommendation
- uncoated grades
- coated grades
- brazed/Cermet

Dimensions in inch

State R or L version

Carbide grades

INSERT Type

S18P

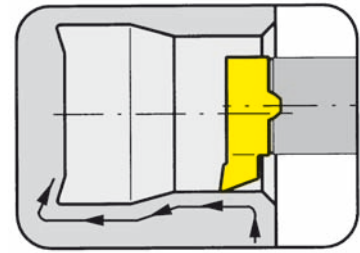

Bore Ø from .689"
 Depth of undercut up to .217"

for use with Toolholder

Type B18P
 BU18P

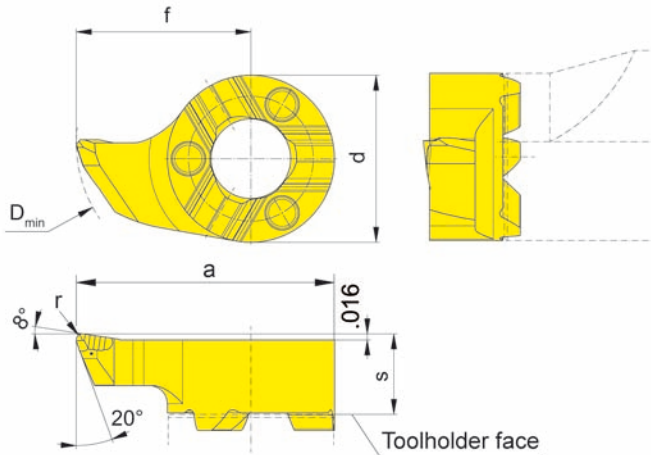

R = right hand version shown

L = left hand version

Part number	r	s	f	a	d	D _{min}	Carbide grades			
							MG12	TN35	Ti25	TH35
LS18P.1815.R2	.008									▲
RS18P.1815.R2	.008					.689				▲
LS18P.1815.R4	.016	.209	.453	.669	.433					▲
RS18P.1815.R4	.016									▲
							P			•
							M			•
							K			•
							S			•
							N			•
							H			•

- ▲ on stock Δ 4 weeks
- main recommendation
- o alternative recommendation
- uncoated grades
- coated grades
- brazed/Cermet

Dimensions in inch

State R or L version

The modified geometry allows boring of bores $\geq \text{Ø} .689''$ and profiling of reliefs as per DIN 509 form E and F.





- short tool changing times
- high precision guaranteed for smooth cutting
- very good surface finish on the threads
- high tool life per edge due to even cutting action

For further information, please contact HORN USA.